

# Power IC Model Library

## PSpice models for the Power Electronics Designer

# Simulation

### Power IC Model Library Key Features

- Analyze large signal effects such as start-up transients, power stage semiconductor stress, and step-load response
- Explore different approaches to transformer, converter, filter, and control structures
- Compute component stresses and test for excessive power dissipation
- Compare circuit characteristics with linear and nonlinear magnetics
- Analyze in both time and frequency domains
- Simulate and analyze your entire power supply without limitations

The Power IC Model Library incorporates over 400 high fidelity time-domain PSpice models for power electronic designs. It gives designers capabilities previously unavailable for many popular parts - the ability to plug in a model, representative of the actual IC, and simulate the switching performance under actual operating conditions.

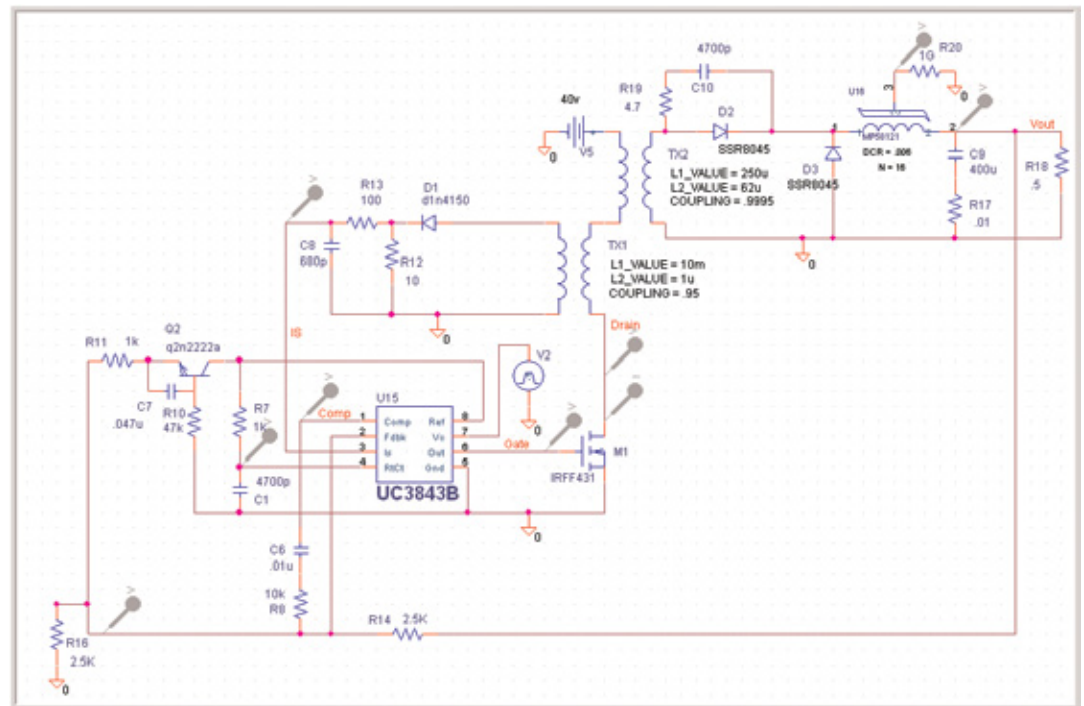

A 50W forward converter circuit using UC3843B PWM and Magnetics MPP58121 core models. The simulation explores the circuit operation as the transformer coupling is changed. The simulation can generate start up or steady state output depending on the settings

### Simulate Switching Performance Under Actual Operating Conditions

The Power IC Model Library, a product of AEI Systems, is specially designed for the Cadence® PSpice® analog and mixed signal simulator. Nonlinear characteristics such as propagation delay, switching speed, drive capability and maximum duty cycle/current limits, startup phenomena are all accurately modeled. You can directly compare the performance of components from different vendors and analyze the effects of different implementations such as peak current

mode control, hysteric current control, low voltage, and low operating current.

Model accuracy and fidelity is assured by AEI System's proprietary relationships with the majority of the top analog IC manufacturers. The models in the Power IC Model Library are verified with bench data under start-up, steady state, line, and load transient conditions. This ensures that the models exhibit the kind of accuracy you expect from PSpice.

# Power IC Model Library

## Improved simulation speed and accuracy

### About AEI Systems

The Power IC Model Library is a product of AEI Systems, a leader in the technology of SPICE and PSpice modeling, and Worst Case Circuit Analysis.

AEI Systems ([www.aeng.com](http://www.aeng.com)) specializes in the design and analysis of power conversion circuits for satellite systems, and also performs analysis for commercial and military, ground based and airborne, analog, digital and mixed mode applications.

EMA Design Automation provides exclusive distribution and support throughout North America for the AEI Systems Power IC Model Library.

### For More Information

For sales and pricing information contact EMA Design Automation, a Cadence Channel Partner.

EMA Design Automation, Inc.  
225 Tech Park Drive  
Rochester, New York 14623

Phone: 877.362.3321  
Fax: 585.334.6693  
eMail: [info@ema-eda.com](mailto:info@ema-eda.com)  
Web: [www.ema-eda.com](http://www.ema-eda.com)

©2011 EMA Design Automation, Inc. All rights reserved in the U.S. and other countries. EMA Design Automation and the EMA logo are registered trademarks of EMA Design Automation, Inc. Cadence, OrCAD, and PSpice are registered trademarks of Cadence Design Systems, Inc. Power IC Model Library and AEI are trademarks of AEI Systems, LLC. All other marks are the property of their respective owners.

AEI Systems® has developed proprietary relationships with the majority of the top analog IC manufacturers and is the sole developer of power IC models in many cases. These relationships ensure that the models exhibit the accuracy you expect from a PSpice simulation.

### Simulate your entire power system

The library includes example application circuits for most of the IC models. Symbols, model libraries and schematic sets are available for both Cadence OrCAD® Capture and Microsim Schematics. You can perform high-speed cycle-by-cycle simulation to show true large-signal performance, simulate current-mode control using the latest accurate modeling techniques, run CCM and DCM converter simulations, analyze control systems including loop gain, input filter design and analysis, and measure power stage loss and stress analysis for all major components. In summary, you can simulate your entire power system.

### The PSpice simulator provides speed increases for complex power supply simulations

Some newly added models in the Power IC Model Library for PSpice incorporate recent PSpice built-in component and building block advances that allow models to take full advantage of PSpice's capabilities. The new version of PSpice also includes speed increases for simulation of math equations and "if-then-else" constructs that are used throughout the model library. The models utilize analog behavioral elements and special Boolean logic elements. Together they greatly reduce the model's simulation runtime, an important factor in SMPS analysis. Most simulations run in just a few minutes. These improvements result in speed increases of 10 to 40% for power supply simulations.

### System requirements

- OrCAD Capture/PSpice version 15.9 or greater
- Microsim Schematics/PSpice version 8.0

### Key Benefits:

- Analyze large signal effects like start-up transients, power stage semiconductor stress, and step-load response
- Explore different approaches to transformer, converter, filter, and control structures
- Compute component stresses and test for excessive power dissipation
- Compare circuit characteristics with linear and nonlinear magnetics
- Analyze in both time and frequency domains
- Simulate and analyze your entire power supply without ANY limitations.

### The PSpice Model Library Contains

- Over 400 Power IC Models (LIB files) including:
  - o Phase shift, Voltage and current mode PWM controllers, Switching regulators, Motor controllers, Power factor correction, and Power MOSFET drivers
  - o Popular parts: UCC3895, HS117/LM117, UC384x, UC152x, UCC380x, LT124x, UC182x, UC1846, TL431, IR2110, UC1854
  - o Linear ICs: AD813x Differential Amps, AD8333 Phase Shifter, AD8331 VGA, ADx36/x37 DC-RMS Converter
  - o Nonlinear Magnetic Cores, Transformers, Opto-Couplers
  - o Texas Instruments, Intersil, ON Semiconductor, Linear Technology, International Rectifier, Micrel, Vishay and more
  - o Spark Gap, Fluorescent Tube and Dead Time Controllable FET Driver Models
- Useful application circuit example schematics for most parts (DSN, OPJ, SCH files)
- Symbols for both OrCAD Capture and Microsim (OLB, SLB files)
- Support for both OrCAD Capture and Microsim Schematics symbol and schematic formats

